

Ionization Chamber Controller with Integrated HV Supply



Features

- Dynamic range <1 pA to 200 μ A
- Integrated digitization and filtering
- Fiber-optic, RS-232 and RS-485 interfaces.
- Integrated calibration test source
- Full control provided of integration modes
- External trigger capability
- Analog monitor output .
- Frequency monitor output (VFC).
- Optional 3 kV high voltage output for ionization chamber biasing.
- Highly compact design

Applications	<ul style="list-style-type: none"> • Ionization chamber readout • Low current and charge measurement
Options	<ul style="list-style-type: none"> • Auxiliary HV output 0 to 3000V,

Specifications

Operating principle	Gated integrator (charge integrating amplifier)
Integration capacitor	Dual, software selectable. Default values 100 pF and 3300 pF.
Input noise	< 100 fA rms + 1 fA rms per pF input load up to 100 pF (1 second integration, 100 pF capacitor)
Input offset	< 10 pA , 15 to 25 C. Offset can be removed by zero subtraction.
Stability	Output drift < 200 fA / C / hour
External accuracy	Better than 0.5% of full scale in use, integration time 500 μ sec to 1 sec, after calibration with built-in current source



Specifications (continued)

Integration time	User selectable, 100 μ sec to 10 sec.
External gate input	TTL 10 kohm impedance
Trigger modes	Internal (autorun), external.
Digitization	16 bit bipolar over +/- 10 V integrator output range
Averaging modes	Multiple conversions per integration; multiple integrations per reading to increase digital resolution up to 20 bits.
Auxiliary HV PSU	(Factory option) 0 to 3000V programmable (polarity and maximum voltage factory selectable), 1 watt max at full voltage and current. Noise and ripple < 0.01%.
Power input	+24V (+/- 2V) DC, 300mA typ, 500mA max.
Controls	Two rotary switches for loop address and comms mode/ baud rate.
Displays	Six status LEDs (power, comms mode, device status). "HV on" LED.
Case material	Stainless steel sheet
Weight	1.2 kg (2.6 lb).
Operating environment	10 to 35C (15 to 25 C recommended to reduce drift and offset) , < 70% humidity, non-condensing, vibration < 0.1g all axes (1 to 1000Hz) Vibration must be as low as possible to measure at the lower limit of the dynamic range.
Shipping and storage environment	-10 to 50C, < 80% humidity, non-condensing, vibration < 2g all axes, 1 to 1000Hz

Interfacing

Interfaces	RS-232 or RS-485, 8-bit ASCII. Selectable baud rate up to 115 kbos. The electrical interface can be set to be RS-232 levels, or full-duplex differential RS-485.
	Fiber-optic loop, 10 Mbit/sec serial, 9-bit asynchronous binary. Ethernet connection to host through A300 or A500 loop controllers.
Host computer	ASCII communications based on SCPI. Diagnostic host program supplied for Microsoft® .net framework. Binary DLLs available for Microsoft® .net, National Instruments™ Lab-view™, Microsoft® C++.and Linux.



Monitor outputs

Number	One, analog voltage One, frequency
Signal type	Analog voltage +/- 10V into 10 kohm. Frequency 0 to 1 MHz TTL into 50 ohm.
Mapping	Signals map the selected nominal full scale current range.

Connectors

Signal input	BNC female.												
HV out	SHV												
External gate in	Lemo coax size 00												
Monitor outputs	Lemo coax size 00 for analog voltage Lemo coax size 00 for frequency												
RS-232 / RS485	Six pin mini-DIN ("PS/2") <table border="1" data-bbox="553 1041 1307 1182" style="margin-left: 40px;"> <tr> <td>1</td> <td>Tx / RS-485 Tx-</td> <td>4</td> <td>n/c</td> </tr> <tr> <td>2</td> <td>Rx / RS-485 Rx+</td> <td>5</td> <td>RS-485 Tx+</td> </tr> <tr> <td>3</td> <td>Gnd</td> <td>6</td> <td>RS-485 Rx-</td> </tr> </table>	1	Tx / RS-485 Tx-	4	n/c	2	Rx / RS-485 Rx+	5	RS-485 Tx+	3	Gnd	6	RS-485 Rx-
1	Tx / RS-485 Tx-	4	n/c										
2	Rx / RS-485 Rx+	5	RS-485 Tx+										
3	Gnd	6	RS-485 Rx-										
Fiber optics	TX & RX ST bayonet, suitable for 1mm plastic fiber or 200 µm HCS fiber.												
Power in	2.1mm threaded jack. Mates with Switchcraft S761K or equivalent.												
Ground	M3 threaded stud												

Ordering information

IC101	IC101 electrometer with user manuals, PSI Diagnostic host software for Windows PCs, calibration data.
-XP30/20/10/05/02 (-XN30/20/10/05/02)	Add auxiliary HV supply positive 3000/2000/1000/500/200 V (negative 3000/2000/1000/500/200 V)



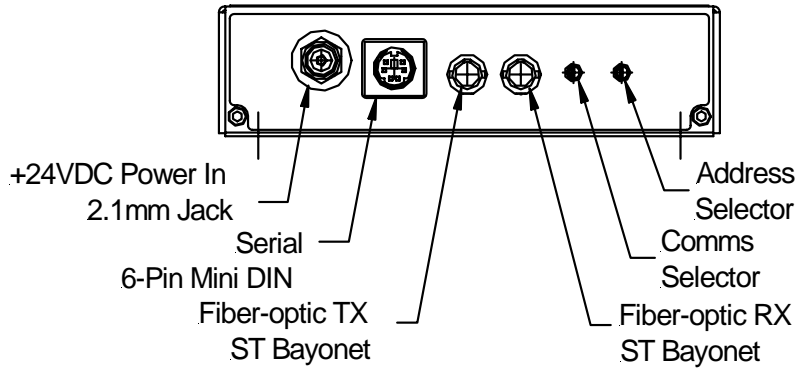
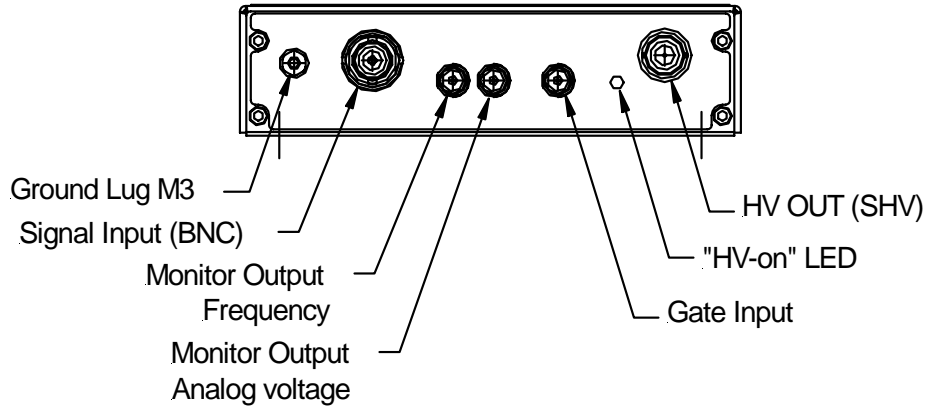

Pyramid Technical Consultants, Inc.,
1050 Waltham, Street Suite 200
Lexington, MA 02421 USA
Tel: +1 781 402 1700 (USA),
+44 1273 493590 (UK)

Email: support@ptcusa.com

www.ptcusa.com

The information herein is believed accurate at time of publication, but no specific warranty is given regarding its use. All specifications are subject to change.

All trademarks acknowledged

IC101_DS_100505



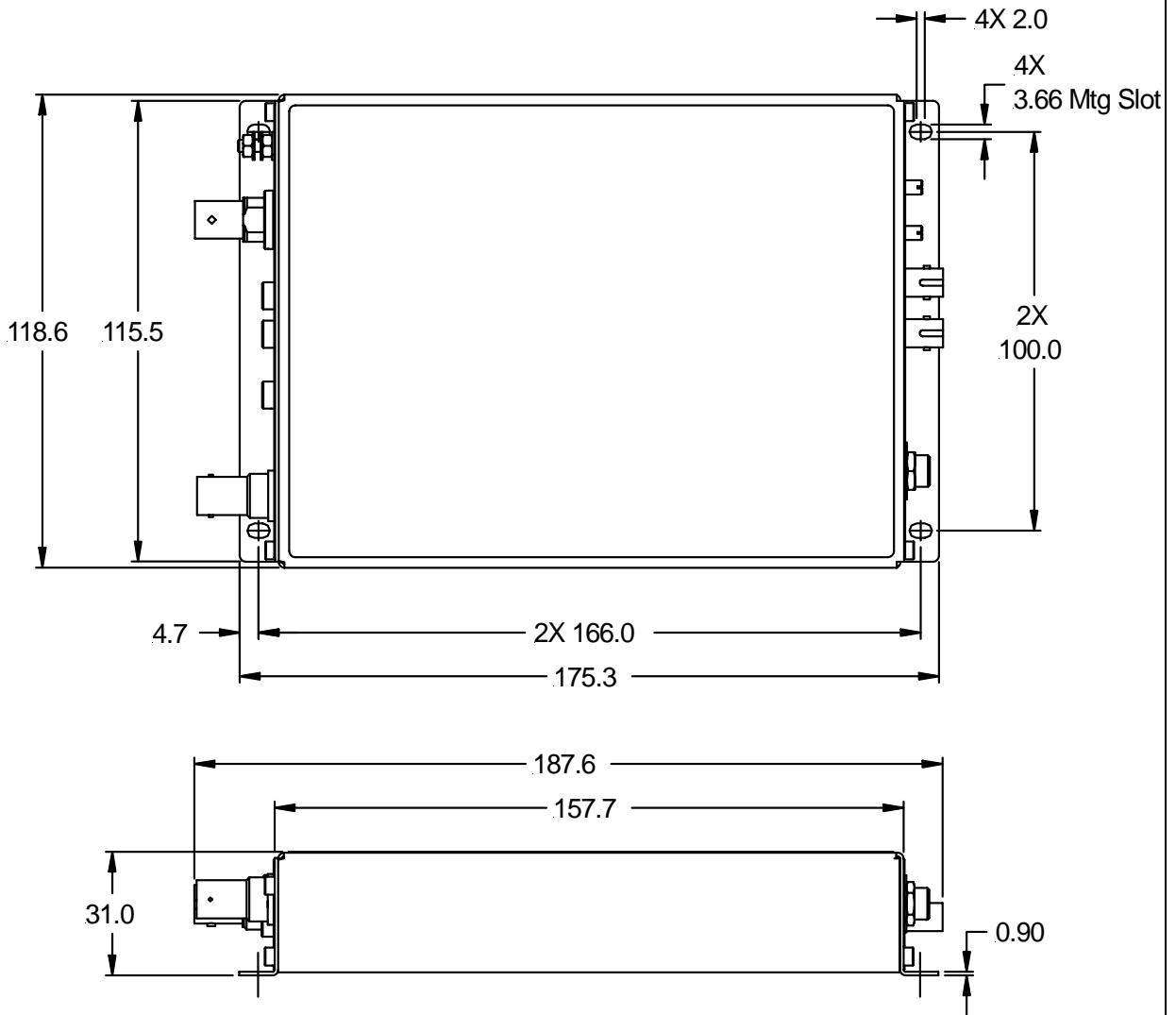

Dims mm

