

Universal Device Interface with 20 mA Current Loop Output



Features

- High resolution and speed in a compact and cost-effective package.
- Permits simple interfacing of existing devices to a fast fiber-optic communication loop.
- Can be mounted on or close to the device being controlled
- Up to sixteen devices can be connected on a single fiber-optic loop
- Very low transition transient on analog output DACs, for compatibility with wideband power supplies.

Applications

- Remote control of power supplies and similar devices over fiber-optic.
- Waveform generation for scanned or swept devices.
- Control of devices across high voltage barriers.
- Connection of multiple devices to a PC host. Each device independently addressable.
- Fully automated systems operating in electrically noisy environments.
- Addition of high-performance remote control to existing systems.

Specifications

Analog output (voltage)	Number of independent outputs	1
	Output voltage range	-10 V to + 10 V
	Output current compliance	+/- 5 mA
	Resolution over full voltage span.	16 bit
	Linearity max deviation over span	<0.1%
Analog output (current)	Number of independent outputs	1
	Output current range	0.0 to 20.0 mA
	Output voltage compliance	+/- 10 V
	Resolution over full current span.	16 bit
	Linearity max deviation over span	<0.1%



Specifications (continued)

Analog input	Number of independent inputs Configuration Input voltage range Input impedance Common mode rejection	2 Differential -10 V to +10 V (software configurable to +/- 5V, 0 to +5V, or 0 to +10V) 10 kohm 80 dB
Digital output	Number of independent outputs Voltage level Maximum current drive capability Output impedance Minimum output pulse length	4 TTL 24 mA 100 ohm 15 nsec
Digital input	Number of independent inputs Voltage level Configuration Input impedance	4 TTL Active low, internal 10 kohm pul- lup to +5 V 10 kohm

Power input	+24V (+/- 2V) DC, 500mA maximum
Controls	16 position rotary switch for address selection
Displays	Status LEDs (power, processor status, comms status)
Case material	Stainless steel sheet.
Weight	0.15kg (0.33 lb)
Operating environment	10 to 35C, < 80% humidity, non-condensing, vibration < 2g all axes, 1 to 1000Hz
Storage environment	0 to 50C, < 80% humidity, non-condensing, vibration < 2g all axes, 1 to 1000Hz



Interfacing and control

Interfaces	Fiber-optic loop, 9600 to 10 Mbit/sec serial, 8 or 9 bit asynchronous binary.
Data rate	Typical read/write rate ≥ 1 kHz, depending upon loop configuration. Rate to A500 host memory (special applications) ≥ 10 kHz.
	Fibre-optic loop to host system interfacing available using loop controllers: A100 (RS-232), A200 (USB), A300 (Ethernet), A500 (Real-time controller)
Host computer	Diagnostic host program provided for PC. Embedded software DLLs available for Microsoft® .NET, Labview and C++.

Connectors

Fiber optics	Two 1mm Avago HFBR ST bayonet																																																				
Power in	2.1mm threaded jack. Mates with Switchcraft S761K or equivalent.																																																				
Signal	25 way DSub female <table border="1" style="margin-left: 40px;"> <tr> <td>1</td> <td>PSU 0V in</td> <td>14</td> <td>+24V DC in</td> </tr> <tr> <td>2</td> <td>Shield (M10 case)</td> <td>15</td> <td>Analog ground</td> </tr> <tr> <td>3</td> <td>Analog In 1 +</td> <td>16</td> <td>Analog In 1 -</td> </tr> <tr> <td>4</td> <td>Digital out 1</td> <td>17</td> <td>Digital out 2</td> </tr> <tr> <td>5</td> <td>Analog In 2 +</td> <td>18</td> <td>Analog In 2 -</td> </tr> <tr> <td>6</td> <td>Analog ground</td> <td>19</td> <td>Analog out 1</td> </tr> <tr> <td>7</td> <td>Analog ground</td> <td>20</td> <td>Analog out 2 (0—20 mA)</td> </tr> <tr> <td>8</td> <td>Analog ground</td> <td>21</td> <td>+5V digital out</td> </tr> <tr> <td>9</td> <td>Digital ground</td> <td>22</td> <td>Digital out 3</td> </tr> <tr> <td>10</td> <td>Digital out 4</td> <td>23</td> <td>Digital ground</td> </tr> <tr> <td>11</td> <td>Digital In 4</td> <td>24</td> <td>Digital In 3</td> </tr> <tr> <td>12</td> <td>Digital In 2</td> <td>25</td> <td>Digital In 1</td> </tr> <tr> <td>13</td> <td>Digital ground</td> <td></td> <td></td> </tr> </table>	1	PSU 0V in	14	+24V DC in	2	Shield (M10 case)	15	Analog ground	3	Analog In 1 +	16	Analog In 1 -	4	Digital out 1	17	Digital out 2	5	Analog In 2 +	18	Analog In 2 -	6	Analog ground	19	Analog out 1	7	Analog ground	20	Analog out 2 (0—20 mA)	8	Analog ground	21	+5V digital out	9	Digital ground	22	Digital out 3	10	Digital out 4	23	Digital ground	11	Digital In 4	24	Digital In 3	12	Digital In 2	25	Digital In 1	13	Digital ground		
1	PSU 0V in	14	+24V DC in																																																		
2	Shield (M10 case)	15	Analog ground																																																		
3	Analog In 1 +	16	Analog In 1 -																																																		
4	Digital out 1	17	Digital out 2																																																		
5	Analog In 2 +	18	Analog In 2 -																																																		
6	Analog ground	19	Analog out 1																																																		
7	Analog ground	20	Analog out 2 (0—20 mA)																																																		
8	Analog ground	21	+5V digital out																																																		
9	Digital ground	22	Digital out 3																																																		
10	Digital out 4	23	Digital ground																																																		
11	Digital In 4	24	Digital In 3																																																		
12	Digital In 2	25	Digital In 1																																																		
13	Digital ground																																																				



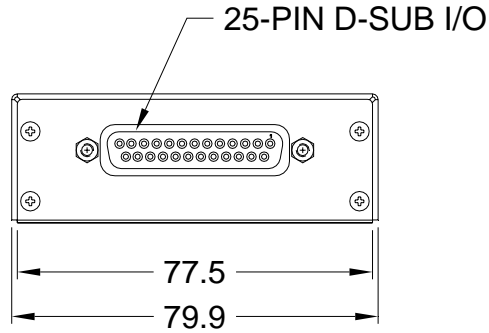

Dims mm

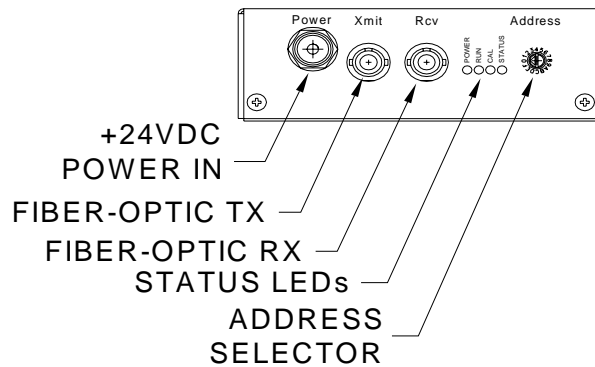

Ordering information

M10	M10 device with two voltage analog outputs, two analog inputs, four digital inputs and four digital outputs. Including PTCDiagnostic host software See separate data sheet.
M10-C	M10 device with one 0-20 mA current output, one voltage analog output, two analog inputs, four digital inputs and four digital outputs. Including PTCDiagnostic host software



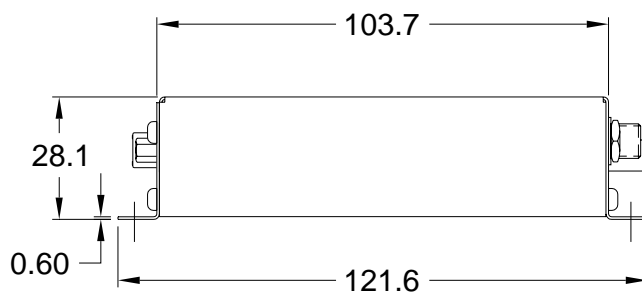
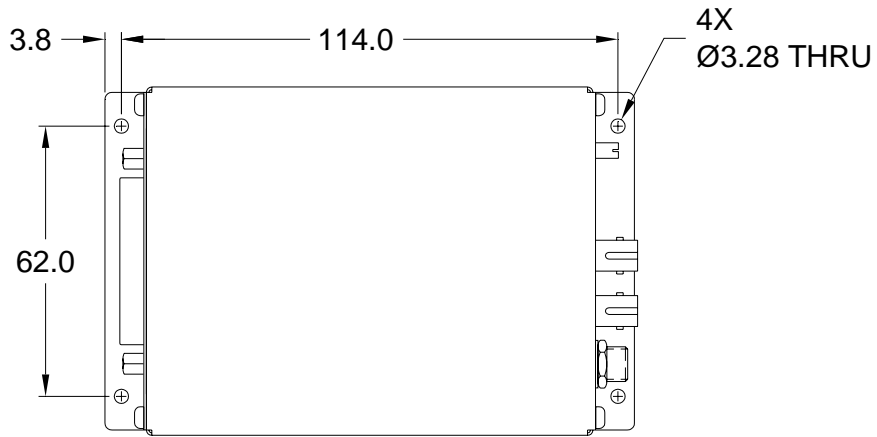

Dims mm

Pyramid Technical Consultants, Inc.,
1050 Waltham Street Suite 200
Lexington MA 02421 USA
Tel: +1 781 402 1700 (USA),
+44 1273 493590 (UK)

Email: support@ptcusa.com

www.ptcusa.com

The information herein is believed accurate at time of publication, but no specific warranty is given regarding its use. All specifications are subject to change. Trademarks and copyright acknowledged.

M10C_DS_080107



Recommended Connection Arrangements

Analog input : differential source

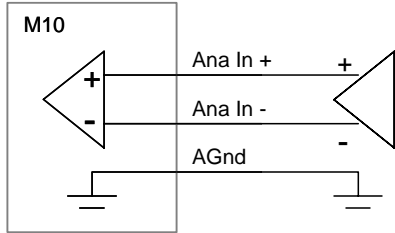

Analog input : single-ended source

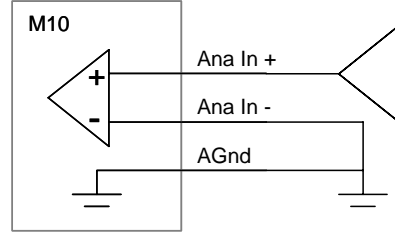

Analog output : differential destination

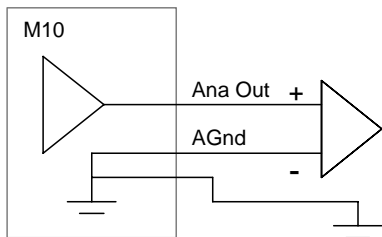

Analog output : single-ended destination

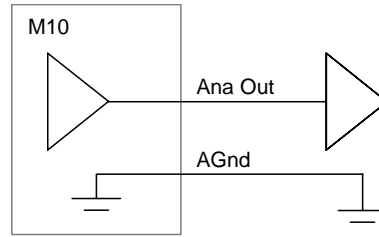

Analog output (0 –20 mA current) : single-ended destination

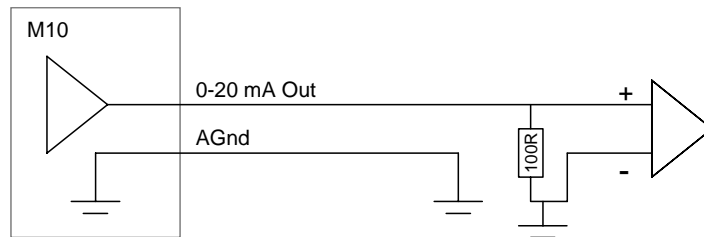

Analog output (0 –20 mA current) : differential destination

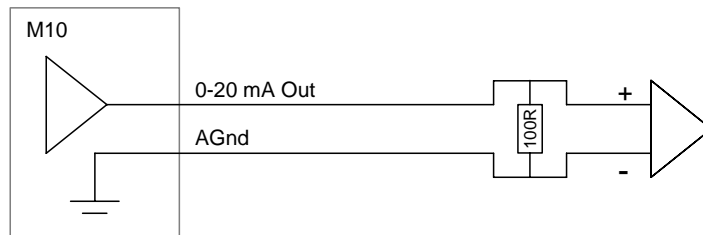

Choose terminating resistor according to required voltage at receiver:

50 ohm	0.0 to +1.0 V
100 ohm	0.0 to +2.0 V
500 ohm	0.0 to +5.0 V
1 kohm	0.0 to + 10.0V



Digital input : TTL input

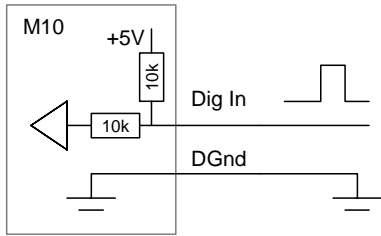

Digital input : volts-free contact

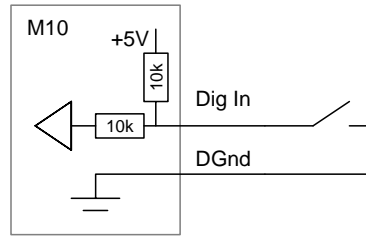

Digital output : TTL load

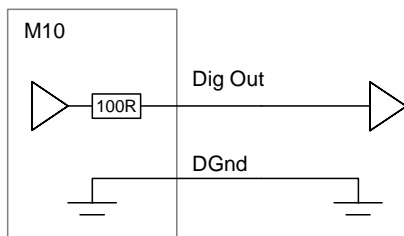

Digital output : optoisolator

